

# ELECTRODERS FOR PROJECTION WELDING NUTS

## プロジェクションナット電極

**W type**

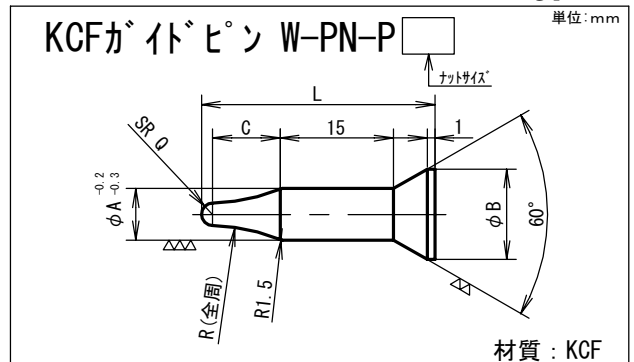
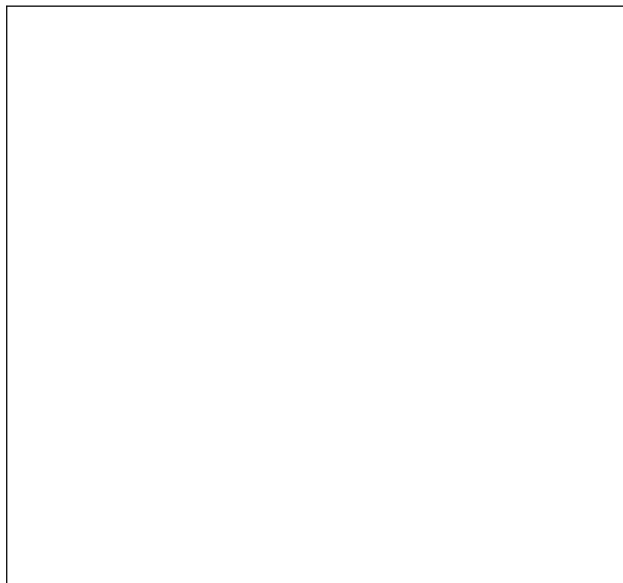

CDNo.	規格	A	B	C	R	Q	L
331001	KCFガイドピン W-PN-P4	5	12	5.5	11.0	2	28.7
331002	KCFガイドピン W-PN-P5	6	12	7.5	15.0	2	29.8
331003	KCFガイドピン W-PN-P6	7	12	9.5	23.6	3	30.9
331004	KCFガイドピン W-PN-P8	9	12	11	21.7	3	31.1
331005	KCFガイドピン W-PN-P10	11	16	12	22.3	4	34.4
331006	KCFガイドピン W-PN-P12	13	16	15	27.0	4	35.7

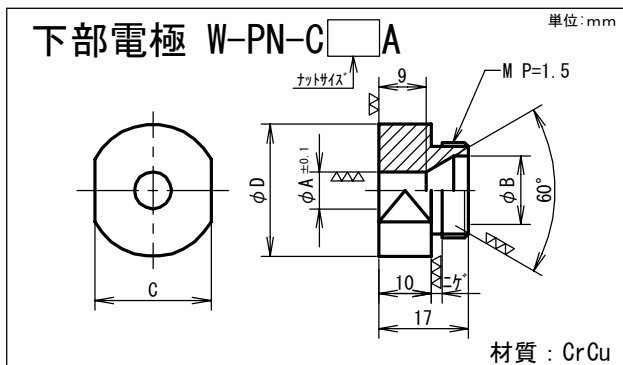

CDNo.	規格	A	B	C	D	M
AA0041	下部電極 W-PN-C4A	5	13	22	25	M18
AA0042	下部電極 W-PN-C5A	6	13	22	25	M18
AA0043	下部電極 W-PN-C6A	7	13	22	25	M18
AA0044	下部電極 W-PN-C8A	9	13	22	25	M18
AA0045	下部電極 W-PN-C10A	11	17	27	30	M22
AA0046	下部電極 W-PN-C12A	13	17	27	30	M22

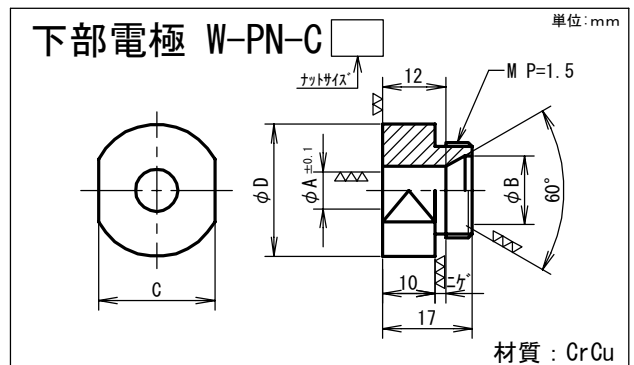

CDNo.	規格	A	B	C	D	M
AA0051	下部電極 W-PN-C4	5	13	22	25	M18
AA0052	下部電極 W-PN-C5	6	13	22	25	M18
AA0053	下部電極 W-PN-C6	7	13	22	25	M18
AA0054	下部電極 W-PN-C8	9	13	22	25	M18
AA0055	下部電極 W-PN-C10	11	17	27	30	M22
AA0056	下部電極 W-PN-C12	13	17	27	30	M22

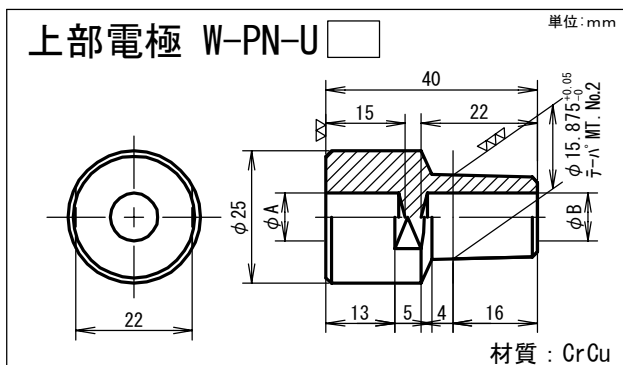

CDNo.	規格	使用ナット	A	B
JB2003	上部電極 W-PN-U3	M10/12	13	10
JB2004	上部電極 W-PN-U4	M6/8	9	9
JB2005	上部電極 W-PN-U5	M4/5	6	9

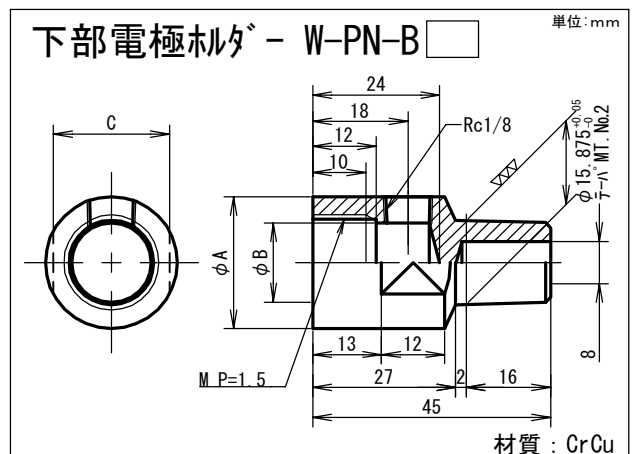

CDNo.	規格	A	B	C	M
AA2002	下部電極ナット - W-PN-B2	30	20	27	M22
AA2003	下部電極ナット - W-PN-B3	25	15	22	M18